

Rivet-Down Nuts with Truss Head

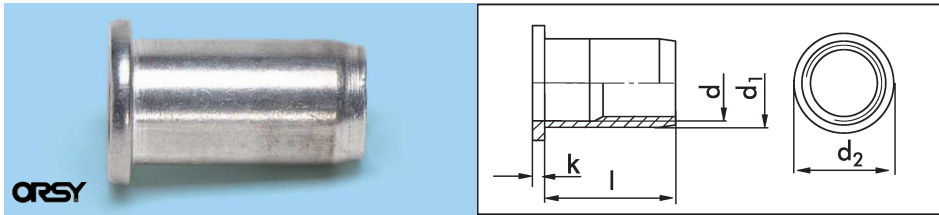

Thread d	Drilled hole dia. in mm	Clamping range in mm	d ₂ in mm	Head height k in mm	d ₁ in mm	l in mm	Art. No.	P. Qty.
M3	5.1	0.3 – 1.8	8.0	0.75	5.0	9.0	0948 20 3	100
M4	6.1	0.5 – 2.0	10.0	0.8	6.0	10.0	0948 20 4	100/500
		2.0 – 4.0	10.0	0.8	6.0	12.0	0948 22 4	100/500
M5	7.1	0.5 – 3.0	11.0	1.0	7.0	12.0	0948 20 5	100/500
		3.0 – 5.0	11.0	1.0	7.0	14.0	0948 22 5	100/500
M6	9.1	0.5 – 3.0	13.0	1.5	9.0	14.5	0948 20 6	100/250
		3.0 – 4.5	13.0	1.5	9.0	16.0	0948 22 6	100/250
M8	11.1	0.5 – 3.0	16.0	1.5	11.0	17.0	0948 20 8	100
		3.0 – 5.5	16.0	1.5	11.0	19.5	0948 22 8	100
M10	13.1	1.0 – 3.0	19.0	2.0	13.0	20.5	0948 20 10	100
		3.0 – 4.5	19.0	2.0	13.0	22.0	0948 22 10	100

Rivet-Down Nuts

Versions: Truss head and countersunk head

Material: Aluminum

- Rivet-down nuts combine 2 types of fastening: A blind rivet connection and an additional screw connection.
- This primarily enables screw connections to be used in relatively thin-walled structural elements.

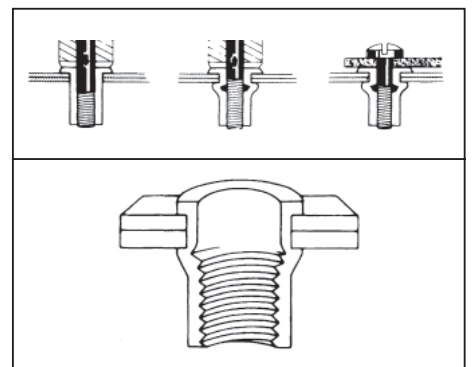

Rivet-Down Nuts with Countersunk Head

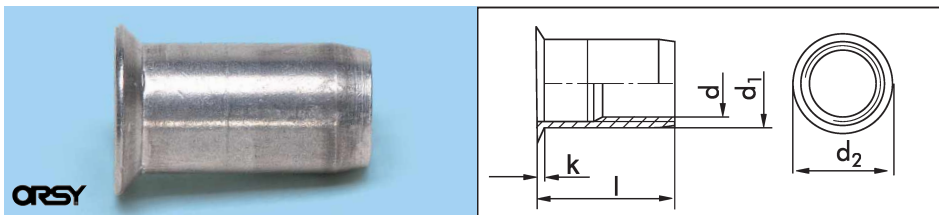

Thread d	Drilled hole dia. in mm	Clamping range in mm	d ₂ in mm	Head height k in mm	d ₁ in mm	l in mm	Art. No.	P. Qty.
M4	6.1	1.5 – 3.5	8.5	1.5	6.0	11.5	0948 32 4	100/500
		3.5 – 5.0	8.5	1.5	6.0	13.0	0948 42 4	100/500
M5	7.1	1.5 – 4.0	9.5	1.5	7.0	13.0	0948 32 5	100/500
		4.0 – 6.5	9.5	1.5	7.0	15.5	0948 42 5	100/500
M6	9.1	1.5 – 4.5	11.5	1.5	9.0	16.0	0948 32 6	100/250
		4.5 – 6.0	11.5	1.5	9.0	17.5	0948 42 6	100/250
M8	11.1	1.5 – 4.5	13.5	1.5	11.0	18.5	0948 32 8	100
		4.5 – 6.0	13.5	1.5	11.0	20.0	0948 42 8	100
M10	13.1	1.5 – 3.0	15.0	1.5	13.0	20.5	0948 32 10	100
		3.0 – 4.5	15.0	1.5	13.0	22.0	0948 42 10	100



Contents: 5 dimensions of rivet-down nuts with truss head, aluminum from M3 – M8 = 506 pieces, 5 mouth pieces with threaded mandrel M3 – M8, blind rivet pliers
Art. No. 0917 1

Art. No. 0964 948 15

Contents: 4 dimensions of rivet-down nuts with countersunk head, aluminum from M4 – M8 = 605 pieces, 4 mouth pieces with threaded mandrel M4 – M8, blind rivet pliers
Art. No. 0917 1

Art. No. 0964 948 25

Suitable installation tools



Rivet-Down Nut Pliers
Art. No. 0917 1



HES 510 Rivet-Down Nut Setting Tool
Art. No. 0948 800



HES 412 Hand Rivet-Down Nut Setting Tool
Art. No. 0964 948 900



HES 512 Rivet-Down Nut Setting Tool
Art. No. 0948 850