

CONJ. LLAVES ESTRELLA ACOD. 6-32 (12 PZS.)





RED LINE

Versión métrica

- Hexágono doble
- DIN 838 / DIN 475-2
- Acero al cromo-vanadio
- Cromado mate

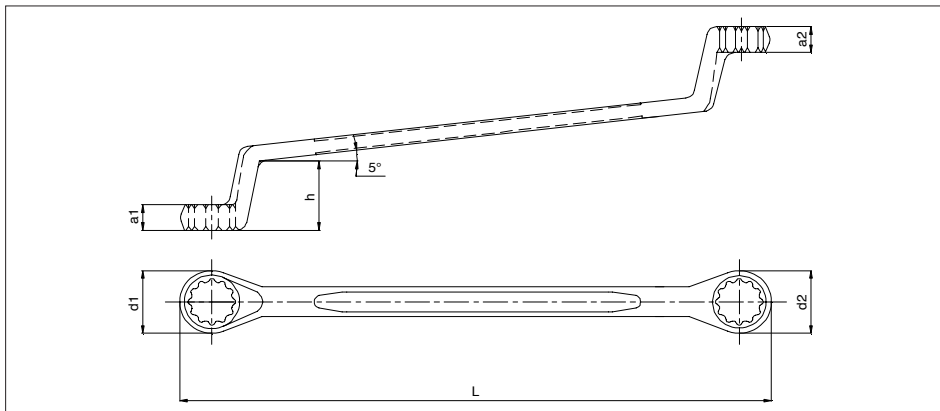
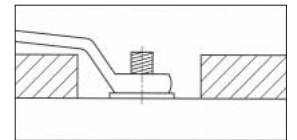
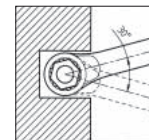
Dimensiones exteriores minimizadas, Su diseño estrecho se caracteriza por sus contornos redondeados y suavizados.



 mm	L mm	a1 mm	a2 mm	dia. d1 mm	dia. d2 mm	h mm	Art.	U/E
6 × 7	175	5	5.8	10.5	11.4	19	5754 305 067	1/50
8 × 9	185	6	7	13.4	14.8	21	5754 305 089	
8 × 10	185	6	7	13.4	14.8	22	5754 305 080	
10 × 11	198	7.4	8.4	16.4	17.9	23	5754 305 101	
12 × 13	215	8.4	9.1	19.5	20.6	25	5754 305 123	1/25
13 × 17	245	10	10.8	20.9	26.2	27	5754 305 137	
14 × 15	228	9.5	10.4	22.2	23	25	5754 305 145	
16 × 17	246	10	10.8	24.5	26	27	5754 305 167	
16 × 18	246	10	10.8	24.5	26	28	5754 305 168	
17 × 19	268	10.8	12.1	26.4	28.4	30	5754 305 179	
18 × 19	268	10.8	12.1	27.5	28.4	30	5754 305 189	1/15
20 × 22	292	11.7	12.5	30.7	33.5	31	5754 305 202	
21 × 23	315	12.2	13.2	31.8	34.8	32	5754 305 213	
22 × 24	315	12.2	13.2	31.8	34.8	32	5754 305 224	1/10
24 × 26	328	12.2	13.4	36.3	39.6	36	5754 305 246	
24 × 27	328	12.2	13.4	36.3	39.9	36	5754 305 247	
25 × 28	342	13.9	14.9	37.4	41.4	35	5754 305 258	
27 × 29	365	14	15.8	39.9	46.3	36	5754 305 279	
30 × 32	370	15.2	16	43.5	46.3	36	5754 305 302	1/5
36 × 41	445	17.3	18.3	52.7	60.2	42	5754 305 361	

Cjto.	 mm	Art.	U/E
12 pzs	6 × 7, 8 × 9, 10 × 11, 12 × 13, 14 × 15, 16 × 17, 18 × 19, 20 × 22, 21 × 23, 24 × 27, 25 × 28, 30 × 32	5754 305 42	1

